

No.	Description	Part No.
1	Knob	09347P-15
2	Shaft Seal Nut	13145P-34
3	Volume Control	09349P-30
4	Jack Cover (with Nut)	09518P-04
5	Neoprene Washer (10/pk)	18900G-39
6	Headset Jack	09228P-03
7	Connector (4 socket)	00084M-04

No.	Description	Part No.
8	Gasket	13176P-03
9	Screws and Nuts (4 ea.)	18900G-01
10	Cap (and nylon cord)	13238P-01
11	Mounting Kit	09865P-03
12	Grommet (4 ea.)	18900G-08
13	Box	26497P-04

# ELECTRICAL SCHEMATIC MODEL U3801

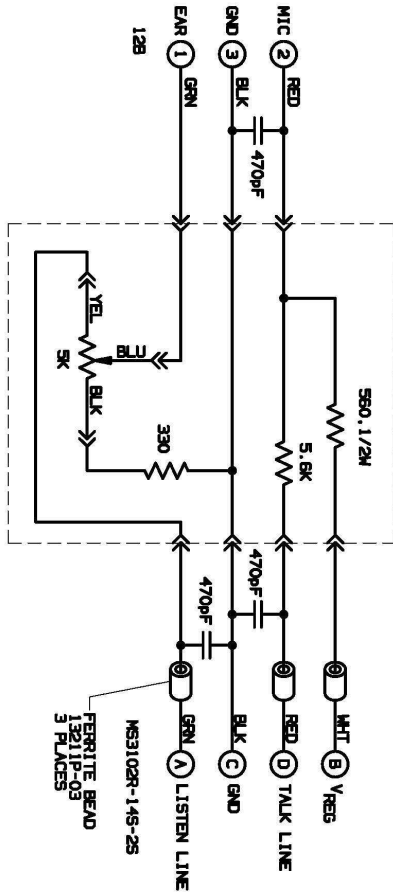

REVISIONS			
SYM	DESCRIPTION	DATE	APPROVED
A	SEE ECN 10314	17 MAR 89	BPD LBF
B	SEE ECN 12781	01 OCT 01	JD DPC
C	SEE ECN 13795	22 APR 06	DL MB

1. ALL RESISTORS ARE IN OHMS, 1/4 WATT, 5% TOLERANCE, UNLESS OTHERWISE SPECIFIED.  
NOTES:  
DO NOT SCALE DRAWING

UNLESS OTHERWISE SPECIFIED: FINAL FINISH ✓ ALL OVER  
ALL DIMENSIONS APPLY AFTER BREAK SHARP EDGES REMOVE ALL BURRS AND BREAK SHARP EDGES

MATERIAL	
TREATMENT	
FINISH	
TOLERANCES UNLESS OTHERWISE SHOWN	
FRACTIONS DECIMALS ANGLES	

1950SP-46 (10-01)

CODE IDENT. NO.	71483	SIZE	B	DRAWING NO.	EL18746G-01	REV	C
CONTRACT NO.							

© 2001 David Clark Company Incorporated

QTY	SYM	PART NO.	DESCRIPTION	MATERIAL	SPECIFICATION
			LIST OF MATERIALS		

DRAFTER	L.E. FAIRBANKS	DATE	25 SEP 84
CHECKER	D.A. FRATKIN	DATE	04 OCT 84
ENG. APPROVAL	J. BERGIN	DATE	05 OCT 84
	E.J. COLLINS	DATE	15 JAN 85

David Clark COMPANY INC.  
WORCESTER, MA 01815-0054

WIRING DIAGRAM  
SCHEMATIC  
MODEL U3801

SCALE \_\_\_\_\_

NT. \_\_\_\_\_

SHEET \_\_\_\_\_ OF \_\_\_\_\_