

**USER MANUAL
Push Back Gateway
U9920-GPB
(P/N: 40993G-01)**

Cautions and Warnings

READ AND SAVE THESE INSTRUCTIONS. Follow the instructions in this installation manual. These instructions must be followed to avoid damage to this product and associated equipment. Product operation and reliability depends on proper usage.



DO NOT INSTALL ANY DAVID CLARK COMPANY PRODUCT THAT APPEARS DAMAGED. Upon unpacking your David Clark product, inspect the contents for shipping damage. If damage is apparent, immediately file a claim with the carrier and notify your David Clark product supplier.



ELECTRICAL HAZARD - Disconnect electrical power when making any internal adjustments or repairs. All repairs should be performed by a representative or authorized agent of the David Clark Company.



STATIC HAZARD - Static electricity can damage components. Therefore, be sure to ground yourself before opening or installing components.



LI-POLYMER - This product is used with Li-Polymer batteries. Do not incinerate, disassemble, short circuit, or expose the battery to high temperatures. Battery must be disposed of properly in accordance with local regulations.

Overview

The U9920-GPB (40993G-01) Push Back Gateway is a portable wireless communication device that when used in conjunction with one or more U9910-BSW (40992G-01), U9912-BSW (40992G-02), or U9913-BSW (40992G-07) Wireless Belt Stations provides communication for up to four users as well as an interface to an aircraft intercom system. Only one gateway is required per system. Up to four belt stations can be connected to one gateway.

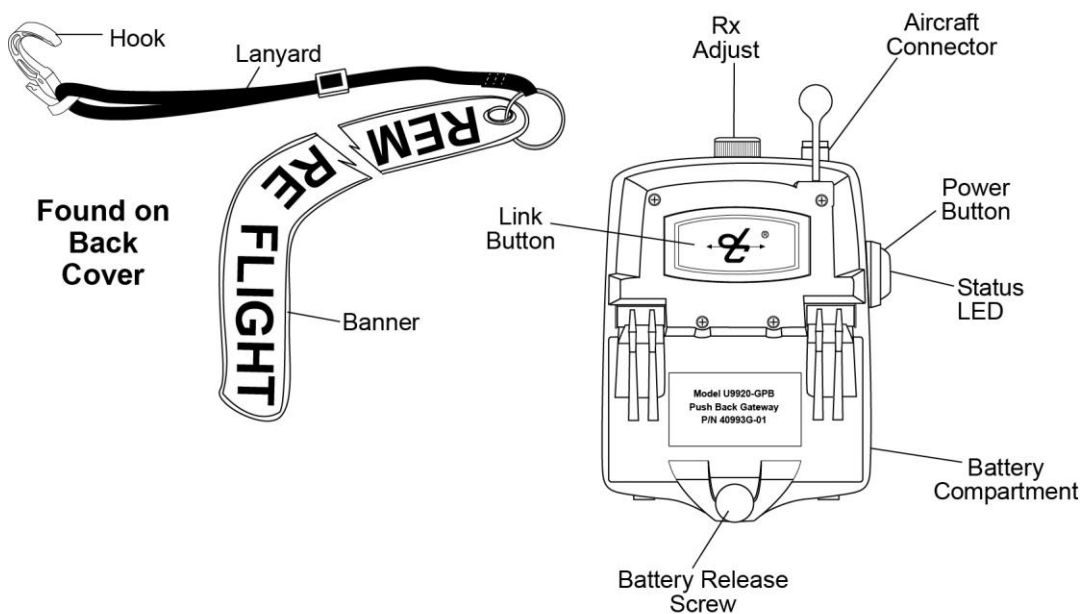

Figure 1: Overview of Gateway

Linking

Before a belt station and a gateway can be connected, they must first be **linked**. As a security measure, the **close-link** feature requires devices to be in proximity of about 1 to 3 ft (0.3 to 0.9m) in order to successfully link. This ensures that the units are not inadvertently linked with other units on the premises.

Linking procedure:

1. Ensure power is on for both U9920-GPB and belt station (see **Power-up/Power-down**)
2. Ensure units are within 1 to 3 ft (0.3 to 0.9m) of each other.
3. Simultaneously (within 1-2 sec) press and release the PTT button on the U9920-GPB and the belt station to link with.
4. Amber LED's will flash on both devices. A momentary red LED indicates a successful close-link.
5. Upon successful link the U9920-GPB will attempt to establish a connection with the belt station.
6. Upon successfully establishing connection the LED on the gateway will flash a green pattern corresponding to the number of belt stations connected.

Tip:

Once linked, the devices will not need to be linked again unless they are purged (see **Purging**).

Each belt station is able to be linked to only one gateway at a time. A gateway can have up to five belt stations linked and be connected to four of those five at one time.

Status Indications

Visual Indications

The power button has a multi-color LED in the center which serves as a visual status indication for the gateway. **Table 1** below lists these states.

Table 1: Visual Status Indications

LED Color	Blink Rate	Status
Red	Solid	Initializing/power up
Red	Once	Connection Dropped
Red	Once	Connection Established
Red	Any	Low battery (approx. 1 hr remaining)
Orange	Slow	Idle/Disconnected
Orange	Fast	Link/Connection in Progress
Orange	Solid	PTT asserted
Green	Slow	Connected (pattern indicates number of belt stations connected)

Audible Indications

The Series 9900 System provides each active system user with a series of audible status indications, in the form of either voice prompts or beeps, which serve to direct the user's attention to related system performance conditions. **Table 2** below lists these conditions.

Table 2: Audible Status Indications

Indication	Status
"Connection Established" (voice prompt)	Indicates an audible connection to a gateway and all mutually linked users
"Connection Lost" (voice prompt)	Indicates when an audible connection has been lost due to the user travelling out of range from its host gateway, or from inadequate line-of-sight conditions
"Connection Deleted" (voice prompt)	Indicates when a user's belt station has been successfully purged from its host gateway.
3 Beep Sequence	Indicates when a user has entered a 'fringe' reception area, where connection could potentially be lost if conditions are not improved.
Continuous Tone (Approximately 5 second duration)	VOX Adjustment Prompt; Indication of higher sensitivity settings during VOX adjustment (see VOX Adjustment Procedure Section)

Operation

Power-Up/Power-Down

To power up the U9920-GPB Push Back Gateway, press and hold the POWER button for approximately two seconds. The LED will turn red and then begin flashing orange. If there are linked belt stations within range, they will automatically connect to the gateway in a few seconds after power up.

To power down the U9920-GPB, press and hold the POWER button for approximately two seconds. The LED will turn red and then turn off. The gateway is now powered down.

Aircraft Interface

- The U9920-GPB is designed for airport push back operations and can be connected to an aircraft intercom system. Once connected, up to four belt station (U9910-BSW or U9912-BSW) users can communicate to the pilot of the aircraft by pressing the PTT button on the belt station. A Push Back Cable is required between the U9920-GPB and the aircraft (see below: **Figure 2** – connection illustration, and **Table 3** – Push Back Cable matrix.)

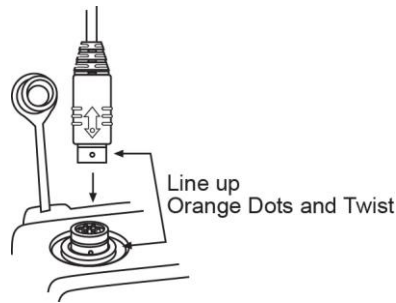

Figure 2: Push Back Cable Connection

Table 3: Push Back Gateway Interface Cable Matrix

Part Number	Configuration
41035G-02	¼" Stereo Plug
41035G-03	U-174/U Plug (Civilian Only)
41035G-04	Dual G.A. Plugs (PJ-055/PJ-068)
41035G-05	U-174/U Plug (Military Only)
41035G-06	7-Pin MS Connector (Military Only)
41035G-08	6-Pin MS Connector (Military Only)
41035G-09	7-Pin MS Connector (Military Only)

The included lanyard and hook assembly, with *Remove Before Flight* banner (see **Figure 1**), facilitates the temporary mounting of the U9920-GPB to an aircraft. Care and judgement should be exercised when attaching to any part of the aircraft so that damage does not occur to the aircraft or the gateway.

Important Note: Proper positioning of the U9920-GPB, to ensure proper line of sight between system users and the gateway, is essential to ensuring optimal wireless range and robustness of communications for all system users during operation.

Establishing proper line of sight typically involves, at a minimum, hanging the gateway low enough under the fuselage and any obstructions (i.e., landing gear doors and/or engines) so that the tow operator and wing walkers can see the unit when they are at their working positions prior to pushing the aircraft.

The lanyard assembly is adjustable in length – from approximately 3 feet (1m) minimum to 6 feet (2m) maximum – to ensure that proper line of sight is achieved when hanging the gateway from the aircraft. To adjust, slide the nylon strap in the appropriate direction through the adjustment buckle, and pull the hook to the opposite end of the lanyard away from the gateway. Attach the hook to the aircraft, check the length for appropriate gateway positioning, and readjust as necessary until optimum positioning is achieved.

WARNING:

ALWAYS REMOVE THE GATEWAY AND ALL ASSOCIATED ITEMS FROM THE AIRCRAFT WHEN OPERATIONS ARE COMPLETE!

Aircraft Level Adjustment

Audio levels can vary between aircraft. To compensate for this, the U9920-GPB has a receive level adjust knob (see **Figure 1**). Turning this knob will increase or decrease the audio level coming from the aircraft and into the wireless intercom. By adjusting this knob, optimum performance can be achieved.

Receive Level Adjustment Procedure

1. Connect U9920-GPB to aircraft interphone via the mating Aircraft Interphone Cable (see Table 3, page 5).
2. Connect at least one belt station to the U9920-GPB gateway and ensure sidetone is present (see belt station User Manual).
3. Press and hold PTT.
4. While holding PTT, begin speaking and slowly turn Receive Level Adjust knob on the U9920-GPB gateway *clockwise* until you hear an echo of your own voice.
5. Turn the Receive Level Adjust knob slightly *counter-clockwise* until the echo stops.
6. Release PTT.
7. You may wish to verify communication with the pilot or someone hard-wired to the aircraft's intercom.

Communication

All connected belt stations will be able to communicate with each other through the U9920-GPB while in range. Additionally, all belt station users will always hear any traffic on the aircraft intercom. To speak over the aircraft intercom, the belt station user must press and hold his/her PTT button (U9910-BSW and U9912-BSW only; U9913-BSW users cannot transmit over the aircraft intercom.) Multiple belt station users may PTT and thus speak over the aircraft intercom simultaneously. Wireless intercom for all connected belt station users is also achieved in this manner. For more information consult the user manual for the belt station.

Note: A non-VOX belt station (U9912-BSW) is recommended for single user wireless push-back systems, as this will eliminate the potential for extremely high and varying noise levels within an airport environment to be unintentionally picked up by the microphone, causing the microphone to become "hot" and introduce background noise into the user's headset.

Range

The range of a belt station and a gateway can be up to 300 ft (100m). If you are in an environment with metal or concrete walls, this range could be reduced. If the belt station enters into a "fringe" reception area, a brief sequence of three beeps will be heard in the headset. This is to serve as an audible indication of a possible disconnection if conditions are not improved. When possible, the user should attempt to regain line-of-sight contact with the controller.

When the belt station travels out of range of the gateway, a voice prompt will indicate that the connection has been lost. To reconnect, simply move back into range and connection with the gateway will automatically be reestablished, also noted by a voice prompt.

Low Battery

Under typical conditions, the battery in the gateway will last up to 24 hours or longer. The Status LED turns red to indicate that the battery is running low. Additionally, a voice prompt ("Gateway Low Battery") is transmitted to all connected belt stations. This voice prompt is not heard by the pilot of the aircraft. At this point, approximately 1 hour of operation remains.

Auto Shut Off

The U9920-GPB will automatically shut off 30 minutes after the last belt station is disconnected.

Purging

In some circumstances it may be desired to "purge" the U9920-GPB of some of its linked belt stations. Typically purging is not necessary unless there are multiple gateways in the same vicinity and you wish to remove a belt station from this gateway and link to a different gateway. A gateway can link up to six belt stations where a belt station can be linked to only one gateway at a time.

Full Purge

A *full purge* is a purge method which clears all links in the gateway. After this procedure no belt stations will automatically connect to this gateway until linked.

Full Purge procedure

1. Power down gateway (see **Power-up/Power-down**).
2. Press and hold PTT button. Do not release.
3. Power up the gateway (see **Power-up/Power-down**).
4. Release POWER button.
5. Release PTT button.
6. Status LED will flash red to indicate successful purge.

Smart Purge

A *smart purge* is a purge in which only unwanted links are removed from the gateway. When this procedure is complete, only belt stations that are connected to the gateway remain linked. All other belt station links will have been removed (see the belt station User Manual for the individual belt station purging procedure when remaining link purging may be necessary.)

Smart Purge procedure

1. Ensure gateway is powered on and functioning.
2. Disconnect all belt stations to be purged (power off the belt stations).
3. Verify the number of green LED flashes on the gateway matches the number of belt stations to be kept linked.
4. Press and hold LINK button on the gateway for 30 seconds until LED quickly flashes red.
5. Release LINK button.

Battery Removal & Charging

All David Clark 9900-series wireless belt stations and battery operated controllers/gateways use a 3.7V Li-Polymer rechargeable battery. This battery is removed by loosening the battery release screw (See **Figure 1**). The batteries are charged with the A99-04CRG 4-bay battery charger (41034G-01). When installing a battery, take care to align the battery properly and fully tighten the screw (see **Figure 3**).

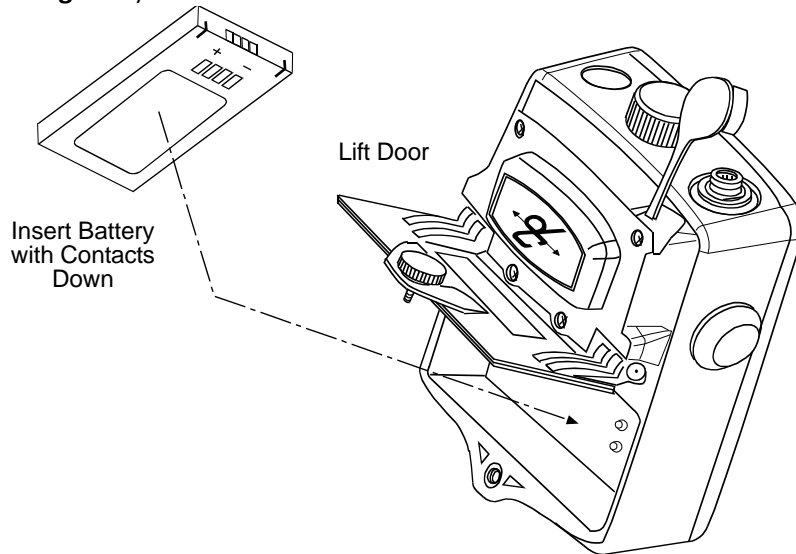

Figure 3: Battery Insertion/Removal

Troubleshooting

Table 4: Troubleshooting

Problem	Solution
Gateway will not turn on	Review <i>Power-up/Power-down</i> procedure Ensure a fresh battery is installed
Cannot link a belt station	Review <i>Registration</i> procedure Ensure units are within 1 to 3ft (0.3 to 0.9m) of each other while linking Try a <i>Full Purge</i>
Cannot speak to aircraft	PTT not pressed

Replacement Parts

- Battery (P/N: 40688G-90)
- Protective skin, orange (A99-02SKN, P/N: 40796G-03)
- Nylon Lanyard/Hook Assembly with Split Ring (P/N: 13376P-04)
- “Remove Before Flight” Banner (P/N: 19540P-31)

Care and Maintenance

The U9920-GPB is not user serviceable. Do not attempt to open the enclosure. If this product requires service, please contact the David Clark Co. Inc. Customer Service department:

- **Phone:** 800.298.6235
- **E-Mail:** serviceWWW@DavidClark.com
- **By Mail:** Customer Service
David Clark Company
360 Franklin Street
Worcester, MA 01604

If necessary, the U9920-GPB may be wiped down with a mild soap and water mixture. Although it is designed as a water-tight device, do not unnecessarily submerge this product in water.

Avoid storage of this product in direct sunlight or high temperature environments.

Specifications

Frequency Range	1920 MHz - 1930 MHz (U.S. and Canada)
Average RF Power Output	4 mW (100mW peak) (U.S. and Canada)
Range	300 ft (100m) line-of-sight (nominal)
Battery Life	24 hrs continuous use (nominal)
Operating Temperature	-14°F to 113°F (-10°C to +45°C)
Storage Temperature	-4°F to 140°F (-20°C to +60°C)
Power Requirements	3.7V @ 100mA nominal
Battery Type	3.7V 2000mAh Li-Polymer

FCC Part 15 Statement

RADIO AND TELEVISION INTERFERENCE

This equipment has been tested and found to comply with the limits for a Class B digital device, pursuant to Part 15 of the FCC rules. These limits are designed to provide reasonable protection against harmful interference in a residential installation. This equipment generates, uses and can radiate radio frequency energy and, if not installed and used in accordance with the instructions, may cause harmful interference to radio communications. However, there is no guarantee that interference will not occur in a particular installation. If this equipment does cause harmful interference to radio or television reception, which can be determined by turning the equipment off and on, the user is encouraged to try to correct the interference by one or more of the following measures:

- Reorient or relocate the receiving antenna.
- Increase the separation between the equipment and the receiver.
- Connect the equipment into an outlet on a circuit different from that to which the receiver is connected.
- Consult the dealer or an experienced radio/TV technician for help.

You may also find helpful the following booklet, prepared by the FCC: "How to Identify and Resolve Radio-TV Interference Problems." This booklet is available from the U.S. Government Printing Office, Washington D.C. 20402.

* In order to maintain compliance with FCC regulations shielded cables must be used with this equipment. Operation with non-approved equipment or unshielded cables is likely to result in interference to radio & television reception.

Industry Canada Statement

This device complies with Industry Canada license-exempt RSS standard(s). Operation is subject to the following two conditions: (1) this device may not cause interference, and (2) this device must accept any interference, including interference that may cause undesired operation of the device.

Unauthorized Changes

Changes or modifications not expressly approved by David Clark Company, Inc. could void the users' authority to operate the equipment.

Usage Restrictions

Due to the UPCS frequencies used, this product is licensed for operation only in the United States of America and Canada, and those countries that have approved the DECT 6.0 Standard.